

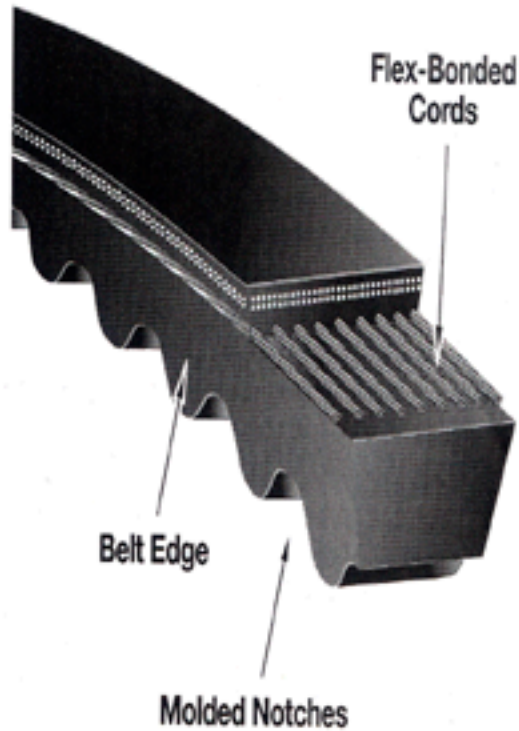

A Tomkins Company



Tri-Power Belts

Constructed with Gates proprietary construction, this belt has a superior combination of flex and load carrying capacity, as well as less stretch resulting in less maintenance.

Markets/Applications

Suitable for all industrial applications, particularly where small or subminimal sheave diameters are required.

Features/Advantages

- ▶ **Notches molded** into the belt during manufacturing, make this belt well suited for drives with smaller diameter sheaves.
- ▶ **Belt Edge** is machined for even sheave groove contact resulting in less slip and wear.
- ▶ **Flex-Bonded Cords** are strongly bonded to the body of the belt resulting in equal load distribution and the absorption of bending stress without cord deterioration.
- ▶ Meets RMA **oil and heat resistant** standards.
- ▶ Meets RMA **static conductivity** requirements.

Recommended Sheaves

Multi-Duty Sheaves

Notes

Tri-Power belts are available in AX, BX, and CX sizes